

OPERATING and MAINTENANCE

INSTRUCTIONS

GRAVELY

LAWN TAMER

40" ROTARY MOWER

40" ROTARY MOWER OPERATING AND MAINTENANCE INSTRUCTIONS

1. ATTACHING THE MOWER TO THE TRACTOR.

The mower is attached to the front of the tractor by four bolts shown at A, Fig. 1. When attaching, tighten securely one of the top bolts before tightening the other three. When detaching the mower from the tractor, remove completely both bottom bolts and one of the top bolts before removing the other top bolt.

When attaching, be sure the engine is stopped, the attachment clutch lever (or attachment clutch control) is at the "OUT" position and the operating levers are in the neutral position.

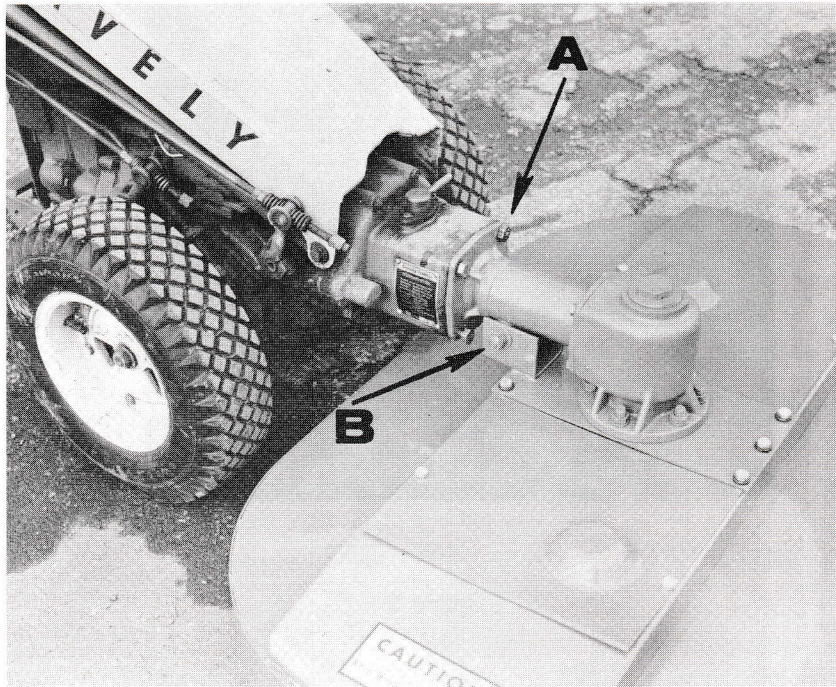

Figure 1

2. SWIVEL ACTION ADJUSTMENT.

The swivel action of the mower is regulated by the bolt and nut shown at B, Fig. 1. To get the proper swivel action, the nut should be tightened until there is no swivel at all to the mower. The nut should then be loosened just enough to allow the mower sufficient swivel action to follow the ground contour under its own weight.

3. CUTTING HEIGHT ADJUSTMENT.

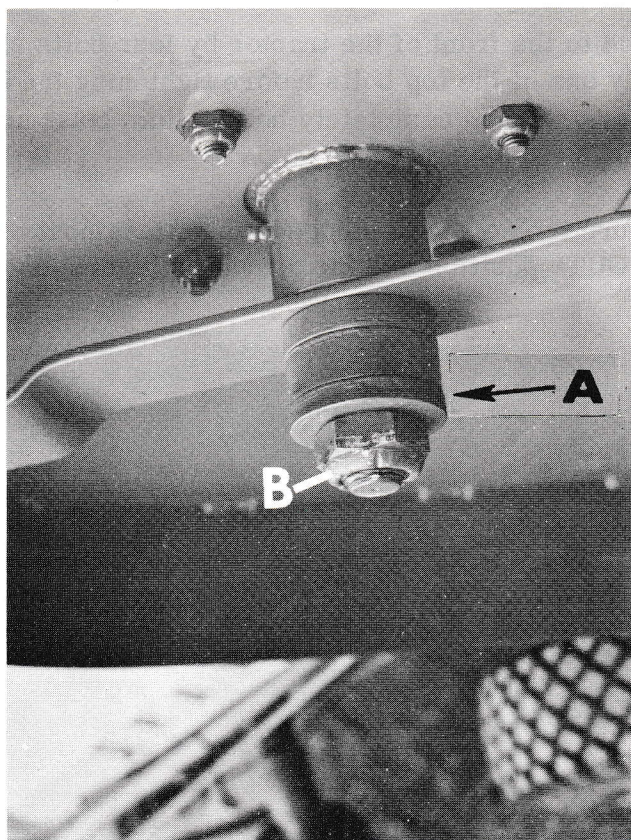

Figure 2

The cutting height of the mower is adjusted by the collars on the rotor shaft shown at A, Fig. 2. The closer the blades are to the bottom of the deck, the higher the cut, and vice versa. Vary the combination of the three collars as you so desire. The cutting height of the mower is from 1 1/2" to 3".

CAUTION: Never put your hands or feet under the deck of the mower while the mower is running, or for an interval after the mower is shut off. Make sure the blades have stopped completely before putting your hands or feet under the deck.

On some mowers, a square hole has been machined in the end of the shaft shown in figure 2. To remove or replace blade easily, insert standard 3/8" socket drive in square hole, and remove or tighten nut with wrench as required.

5. BLADE SHARPENING.

Use a file or grind stone to sharpen the blade. Try to follow the same bevel as the originally sharpened cutting edge, although the precise degree of the bevel is not critical. Dull blades will beat the grass and will require more power to operate the mower.

CAUTION: When grinding the blade, over heating can partially remove the temper from the cutting edge. Equal amounts should be removed from each cutting edge to maintain proper balance of the blade.

6. DRIVE LUBRICATION.

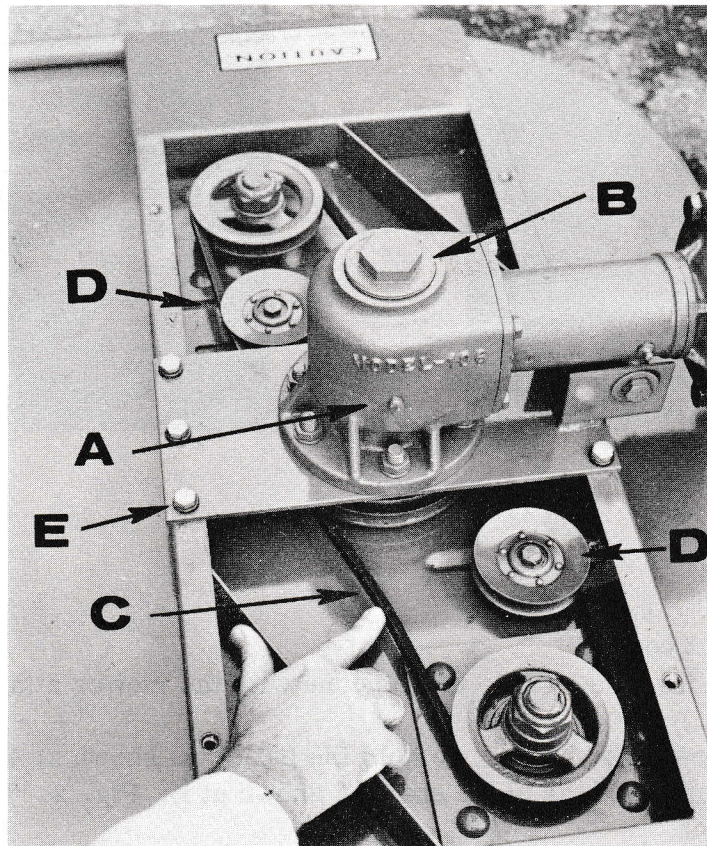

Figure 5

Check the gear housing oil level every four hours of operation by removing the oil level plug shown at A, Fig. 5. If oil runs out, the oil level is alright, if not, oil must be added until the proper oil level is obtained.

To add oil, remove the oil filler plug shown at B, Fig. 5, and pour through the hole until oil begins to run out the oil level hole. Replace both plugs before operating the mower.

Use Mobilube EP-140 (SAE 140) lubricant. Use a good grade of lubricant occasionally in the grease fitting of the swivel casting.

4. REMOVING THE BLADES FROM THE MOWER.

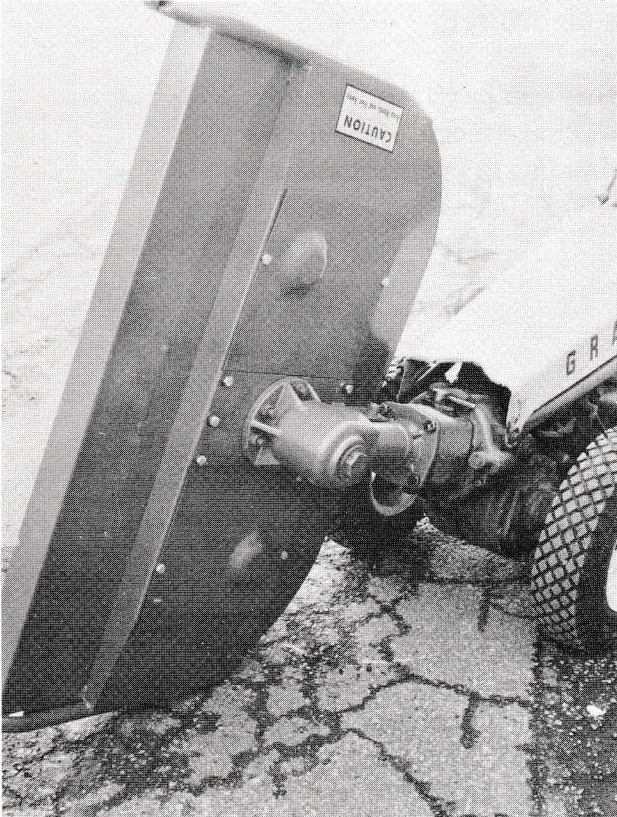

Figure 3

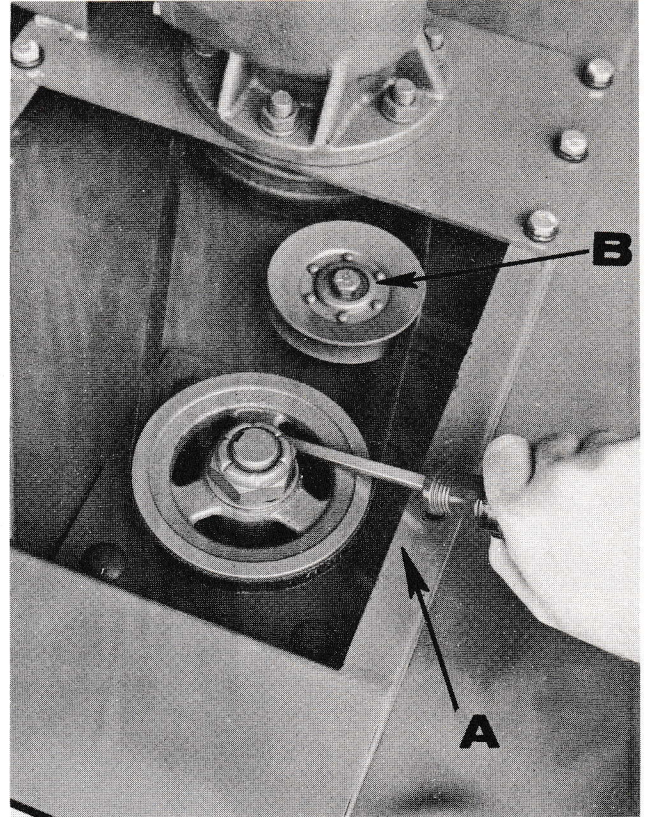

Figure 4

- (A) Remove both belt covers.
- (B) Stand mower on its side. (This can be done with the mower attached to the tractor as shown in Fig. 3.)
- (C) Use a large screw driver, etc., to hold the pulley as shown at A, Fig. 4, while loosening the nut on the bottom of the blade shaft as shown at B, Fig. 2. It is a conventional right handed thread nut.

CAUTION: Never have the mower in gear with the tractor when removing the blades from the mower. With the right conditions, any clockwise rotation of the blades could cause the tractor engine to start.

The Gravely triple-purpose wrench, available from your Gravely representative, was designed to remove the nut on the end of the blade shaft with a minimum of effort. It can also be used for the removal of the blade on the 30" Rotary Mower and on the tine shaft nut on the Rotary Cultivator.

7. BLADE SPINDLE LUBRICATION.

Blade spindles should be lubricated every 10 hours of service with Mobilgrease MP. Apply lubricant through the grease fitting until lubricant starts to come out the vent hole on the opposite side of the spindle.

No lubrication is required for the two belt tightening idler pulleys.

8. BELT ADJUSTMENT.

The belts are in proper adjustment when the mower is delivered. Loosening of the belts is seldom required, except when replacing a belt. However, from time to time you will need to tighten the belts, this is indicated by the mower improperly cutting the grass over areas within its swath. (This condition can also be caused by the safety clutch being out of adjustment.)

The belt adjustment can be made by first removing the belt cover. Then loosen the bolt on top of the idler pulley shown at B, Fig. 4. After loosening, the pulley can be moved in either direction to loosen or tighten the belt. There is an idler pulley for each belt.

When the belts are in proper adjustment, by applying moderate pressure at its mid-point shown at C, Fig. 5, you should be able to deflect the belt about 1/2"

9. BELT REPLACEMENT.

- (A) Remove both belt covers.
- (B) Loosen both idler pulleys shown at D, Fig. 5.
- (C) Remove belts from around blade spindle and idler pulleys.
- (D) Remove the five bolts holding the drive mounting plate to the deck shown at E, Fig. 5. Remove the drive and belts.
- (E) Replace belts by reversing the above procedure and adjust the belts. (See Belt Adjustment)

Put new belts on drive pulley before re-attaching drive plate to mower.

10. SAFETY CLUTCH

The mower is equipped with a safety clutch shown at A, Fig. 6. This clutch will stall the mower if the blades strike a solid obstacle, preventing damage to the tractor, and limit damage that might occur to the mower.

The clutch is set to withstand a clutch capacity of 45-50 ft. lbs. of slip torque. This can be increased or decreased by changing the tension on the six springs around the bolts on the clutch.

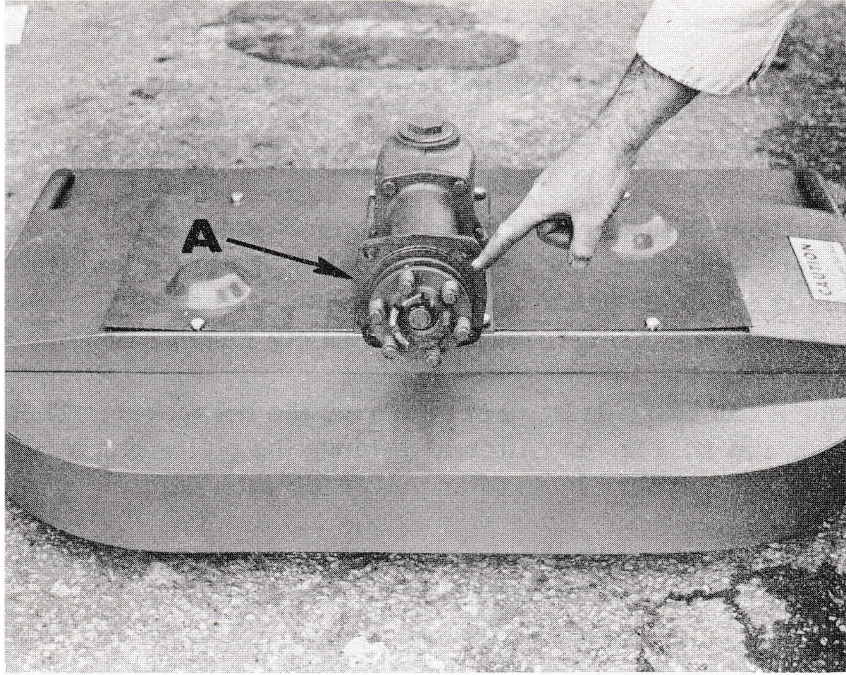

Figure 6

11. REMOVABLE DECK SIDE.

The mower is equipped with a removable side which can be removed when mowing high, heavy weeds, or thick tough grass of considerable height, which will give better mowing results.

CAUTION: It is recommended that this side not be removed unless absolutely necessary. When this is done, there is the danger of rocks, tin cans, metal objects, etc., being thrown from under the hood. Never mow with the side removed in public places or where persons or property can be injured or damaged by materials thrown from under the hood.

40" Rotary Mower

<u>Item</u> <u>No.</u>	<u>Part No.</u>	<u>Description</u>	<u>No.</u> <u>Req'd.</u>
1	9214	Top Deck Weldment	1
2	151-S	Hex Head Cap (Right)	1
2-B	124-S	Hex Head Cap (Left)	1
3	9231	Idler	2
4	9235	Idler Spacer R.H.	1
5	9232	Idler Nut	2
6	9234	Idler Spacer L.H.	1
7	9200	Spindle Bearing Housing Weldment	2
8	9245	Bearing Cap (L44610)	4
9	9246	Bearing Cone (L44643)	4
10	9206	Bearing Seal	2
11	9203	Rotor Shaft	2
12	9206	Bearing Seal	2
13	9213	Square Key	2
14	9204	Seal Ring	2
15	9207	Rotor Pulley	2
16	W-14	Flat Washer	2
17	230-N	Nut	2
18	9205	Dust Shield	2
19	9211	Blade Spacer Collar 3/4"	2
20	9210	Blade Spacer Collar 1/2"	2
21	9209	Blade Spacer Collar 1/4"	2
22	9212	Blade	2
23	W-14	Flat Washer	2
24	230-N	Nut	2
25	6-CB-07-C	Square Neck Carriage Bolt	8
26	NTUO-6-C	Nut	8
27	9256	Belt Cover	2
28	179-S	Hex Head Cap Screw	4
29	9223	Skid	2
30-31	5-CH-7-C	Hex Head Cap Screw	4
32	9240	Drive Belt	2
34	9258	Hex Head Cap Screw	5
35	9259	Lockwasher	5
36	9260	Flat Washer	4
NS	802-A	Set Screw for 9207 (Item 15)	2
NS	9250	Grease Fitting for 9200 (Item 5)	2

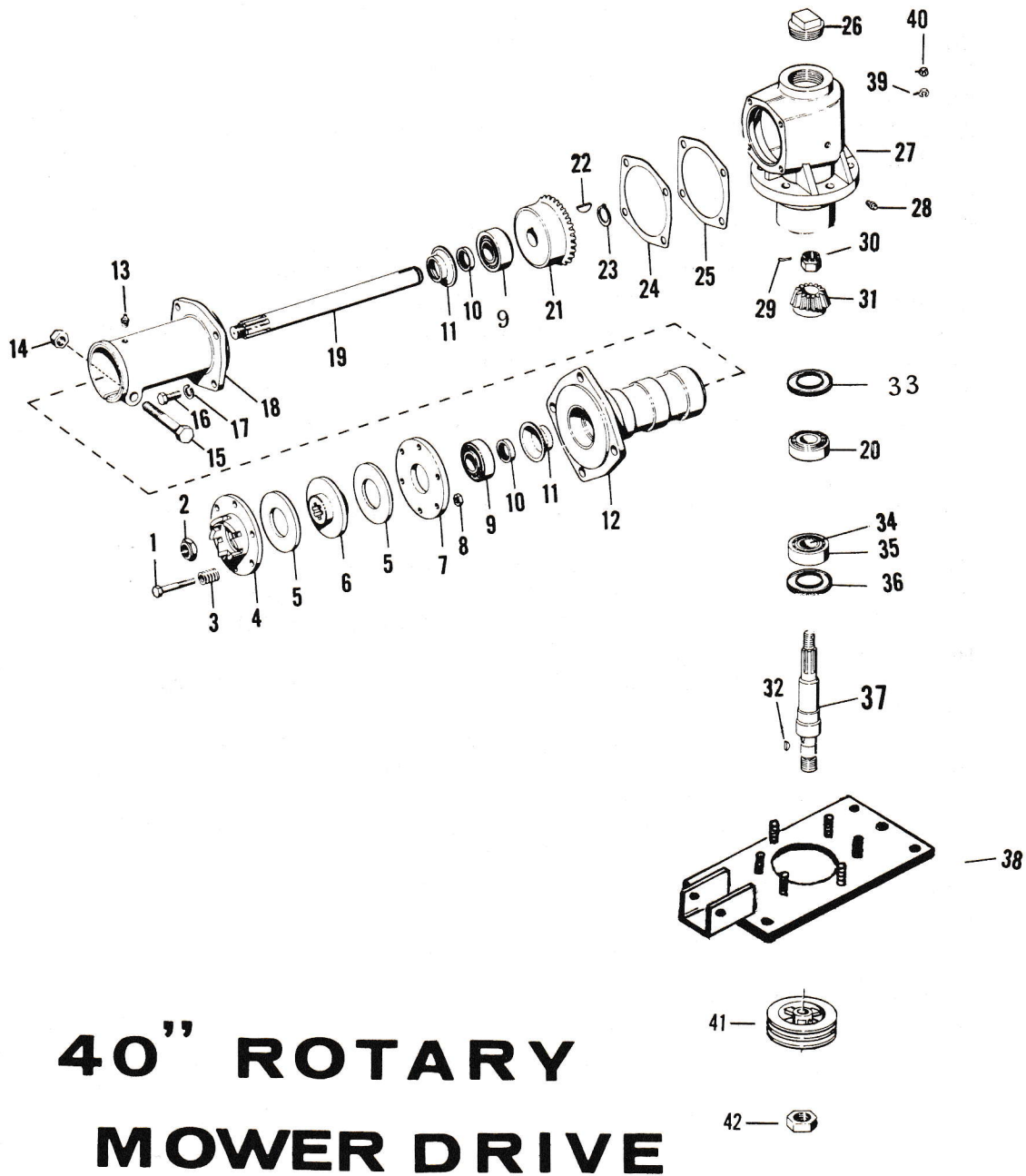

40" ROTARY MOWER DRIVE

40" Rotary Mower Drive

<u>Photo No.</u>	<u>Part No.</u>	<u>Description</u>	<u>No. Req'd.</u>
1	SC-37	Spring Bolt, Safety Clutch	6
2	227-N	5/8"-18 NF Nut, Safety Clutch to Drive Shaft	1
3	SC-35	Spring, Safety Clutch	6
4	SC-30	Dog Plate, Safety Clutch	1
5	SC-34	Friction Washer, Safety Clutch	5
6	SC-33-SA	Drive Plate, Splined, Safety Clutch	6
7	SC-32	Back Plate, Safety Clutch	1
8	215-N	Jam Hex Nut, Safety Clutch	6
9	RB-113-R & RB-113-C	Timken Roller Bearing, For Swivel Casting	2
10	OS-112	Oil Seal, Swivel Casting	2
11	A-474	Oil Seal Retainer	2
12	A-148	Drive Shaft Housing	1
13	903-G	Grease Fitting, Swivel Casting	1
14	241-N	1/2" - 13 NC Nut, for 172-S Screw	1
15	8CH30C	1/2" - 12 NC Bolt, Swivel Casting Clamp	1
16	110-S	Hex, Hd. C p Screw, Swivel Casting to Gear Hsg.	4
17	305-W	Lock Washer, for 110-S Bolts	4
18	A-149	Swivel Casting	1
19	A-475	Drive Shaft, in Swivel Casting	1
20	RB-118-R & RB-117-C	Bearing	2
21	RO-341	Bevel Gear, (large size) Mates with RO-342, 27 tooth 13/16" bore	1
22	510-K	Woodruff Key for RO-341 Gear	1
23	RR-110	Snap Ring for RO-341 Gear to Shaft	1
24	SH-114	Shim (.020 thickness)(or.005 thickness)	1
25	M-488	Gasket	1
26	706-VP	Vented Oil Filter Plug, for Gear Housing	1
27	9236	Gear Housing	1
28	701-P	Oil Level Plug, for Gear Housing	1
29	607-C	Cotter Pin, for 219-N Pinion Nut	1
30	219-N	Pinion Nut, for RO-342 Gear	1
31	RO-108	Bevel Pinion, Small Size, Mates with RO-341, 15 tooth, 13/16" bore	1
32	9239	Drive Sheave Key	1
33	RO-110	Shim	1
34	RB-112-C	Timken Bearing Cone, Rotor	1
35	RB-110-R	Timken Bearing Cup, Rotor	1
36	RO-344	Rotor Oil Seal, 1-3/8" I.D.	1
37	9237	Rotor Shaft	1
38	9226	Mounting Plate Weldment	1
39	308-W	Lock Washer	6
40	211-N	Nut	6
41	9238	Drive Sheave	1
42	229-N	Nut	1